

S4 National 5 Homework
Gradient & Straight Line

Name

Class

Mark

Q1. Calculate the gradients of the lines (a) AB and (b) CD shown below.

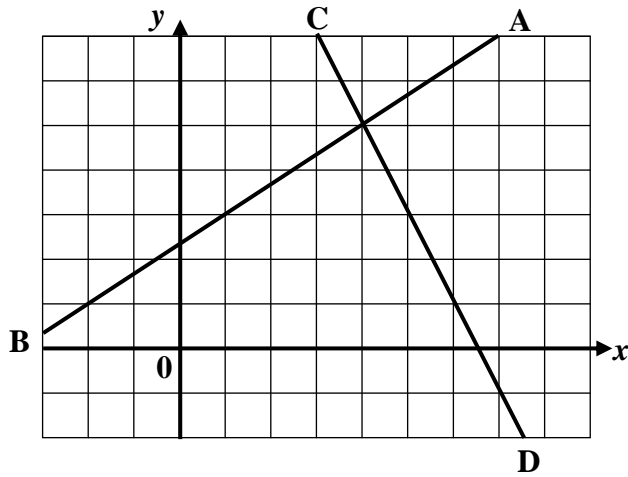

(a)

(b)

Q2. A line passes through the points A(-2, -4) and B(8, 1).

(a) Find the gradient of the line AB.

(b) Find the equation of the line AB.

Q3. Find the equation of the line passing through P(4, 6) which is parallel to the line with equation $4x - 2y + 6 = 0$.

- Q4.** A straight line has equation $3y - 2x = 6$.
Find the gradient and y -intercept of the line.

- Q5.** The graph shows the relationship between P and Q .
(a) Find an equation connecting the two variables.

- (b) Find P when $Q = -7$.

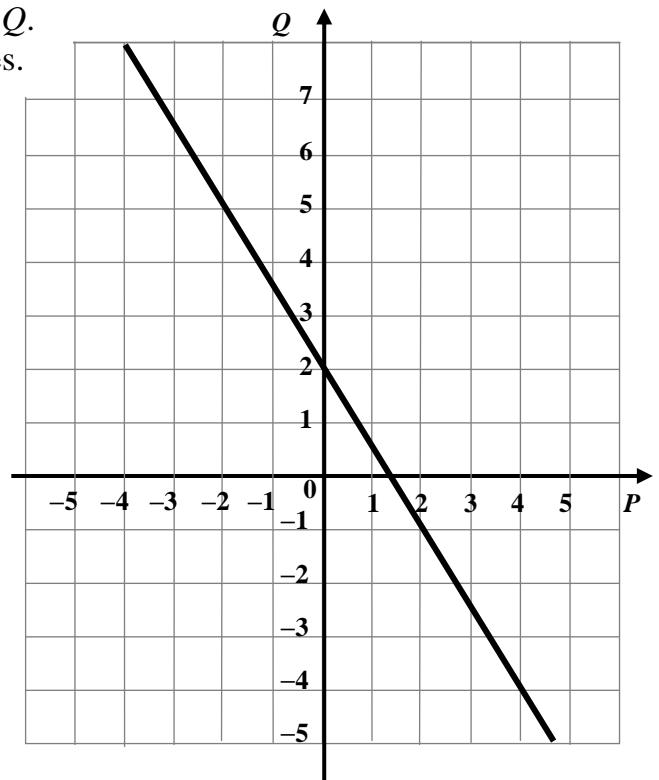

- Q6.** The cost of hiring a taxi is £3 plus 50p for each mile.
(a) Complete the table below.

Miles (M)	0	1	2	3	4	5	6
Cost (£C)							

- (b) Draw the graph of C against M .
(c) Find the equation of the line and use it to calculate the cost of a journey of 10 miles.

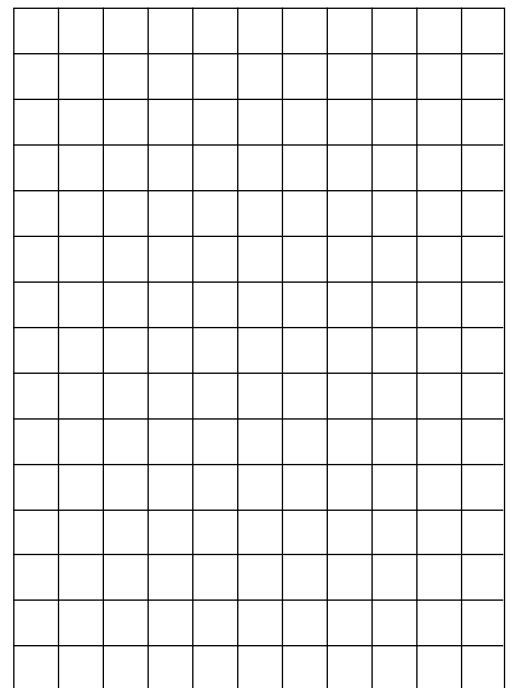

S4 National 5 Homework
Functions & Graphs 1

Name

Class

Mark

Q1. A function is defined as $f(x) = x^2 - 4$. Evaluate

(a) $f(-1)$

(b) $f(0)$

(c) $f(9)$

(d) $f(2a)$

(e) $f(-a)$

(f) $f(a + 1)$

Q2. A function is defined by the formula $g(x) = 12 - 5x$

(a) Calculate the value of $g(5) + g(-2)$

(b) If $g(k) = 14$, find k .

(c) If $g(t^2) = -68$, find the value(s) of t .

Q3. A function is defined as $f(x) = x^2 + 3$

Find a simplified expression for $f(a + 2) - f(a - 5)$

S4 National 5 Homework
Functions & Graphs 2

Name

Class

Mark

Q1. A linear function is defined as $f(x) = \frac{1}{2}x - 2$.

Show this function on a graph.

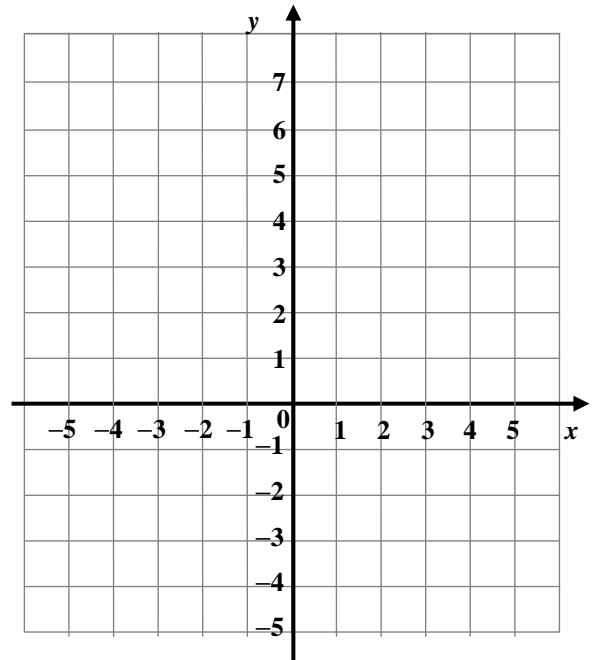

Q2. (a) Draw the graph of the function $f(x) = x^2 + 2x - 8$, where $x \in \mathbb{R}$, for $-5 \leq x \leq 3$ on the diagram on the right.

(b) State

i) the roots of the quadratic function;

ii) the equation of the axis of symmetry;

iii) the coordinates and the nature of the turning point;

iv) the point at which the graph cuts the y-axis;

v) the range of the function.

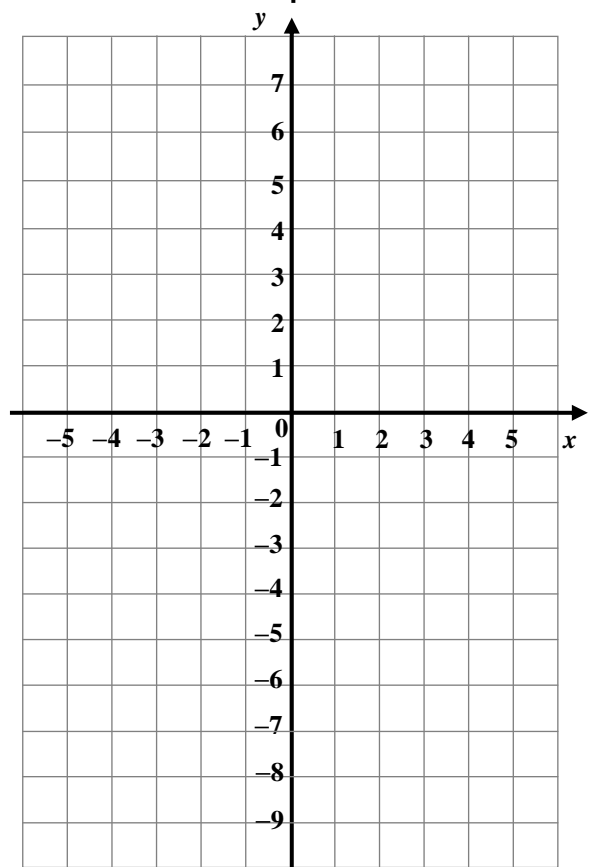

Q3. (a) A syndicate wins £180 on the lottery. Complete the table to show how much the winnings (y) would be for different numbers of members in the syndicate (x).

x	1	3	5	6	9	10	12	15	20
y									

(b) Show the results on a graph.

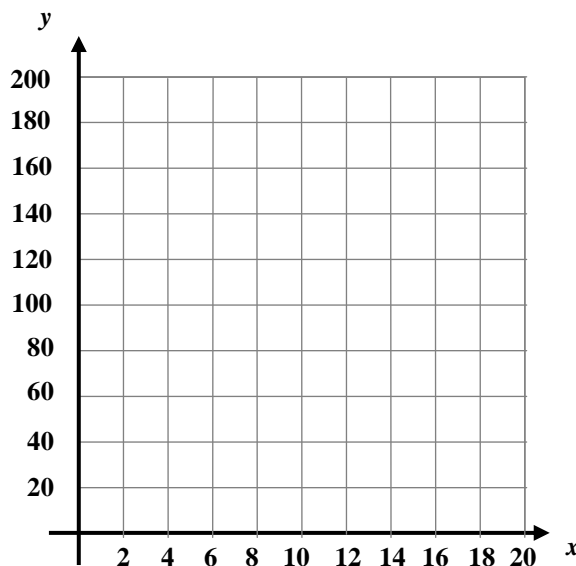

(c) Write down the equation of the graph.

Q4. Match each sketch with its equation.

A. $y = 4 - \frac{1}{2}x$

B. $y = \frac{20}{x}$

C. $y = 0.25x^2$

D. $y = 3x + 2$

E. $y = x^2 - 3$

F. $y = 4 - x^2$

G. $xy = -5$

H. $y = 2x^3$

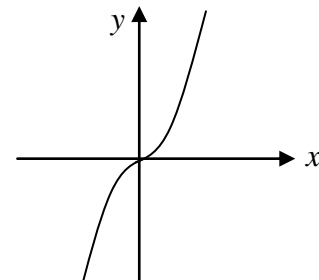
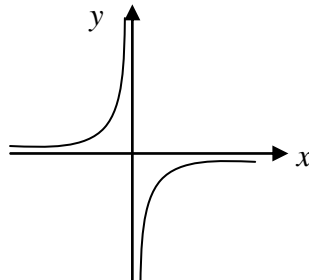
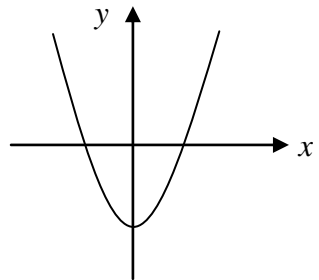
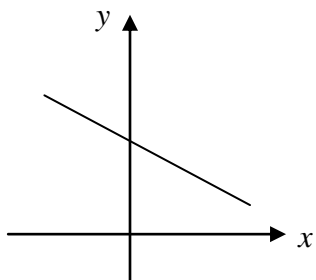
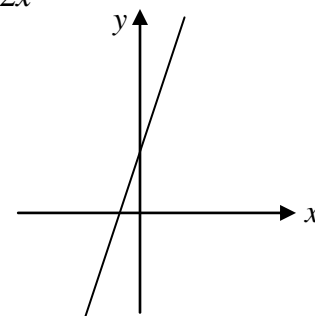
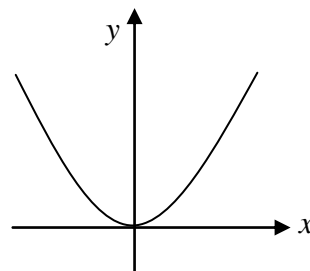
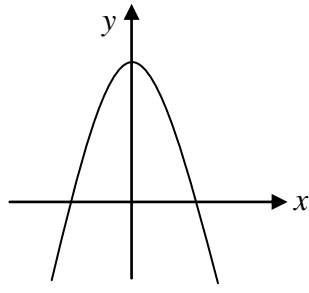
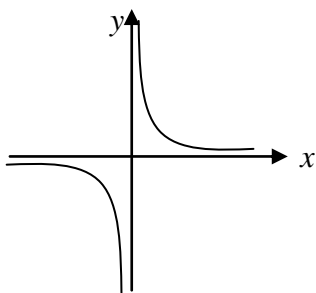

S4 National 5 Homework
The Circle 1

Name

Class

Mark

Q1. In the diagrams below the lines AB (and BC) are tangents to the circles centre O. Calculate the sizes of the marked angles.

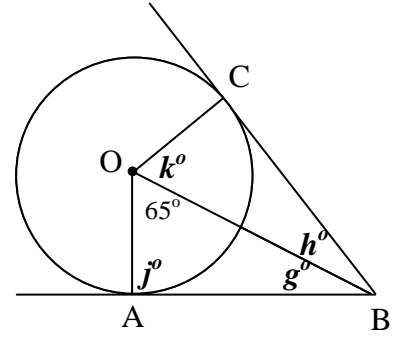
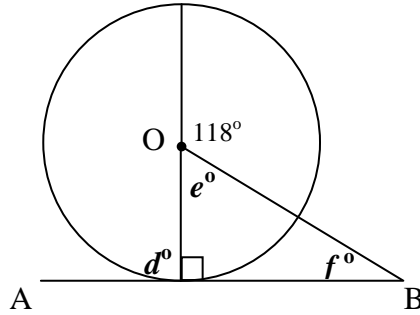
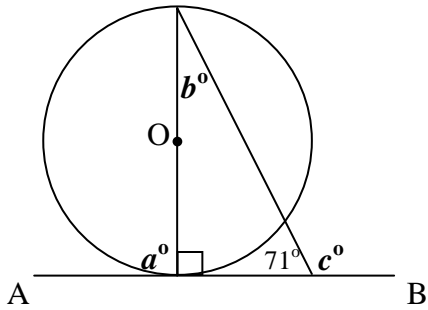

(a)	(b)	(c)	(d)	(e)
(f)	(g)	(h)	(j)	(k)

Q2. In each of the diagrams below, PQ is a tangent which touches the circle at R. Calculate x .

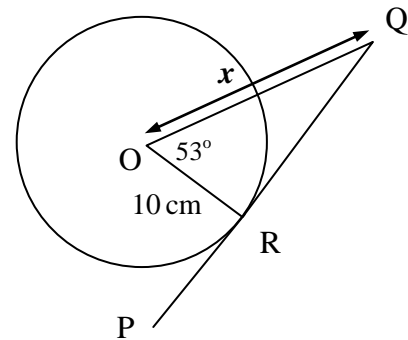
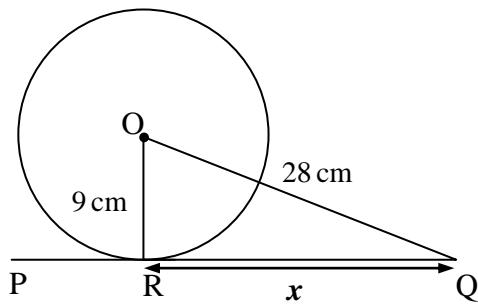

- Q3.** A circular clock is suspended by two wires from a point 25 cm above its centre. The wires are tangents to the circle. The radius of the clock is 10 cm. Calculate the length of a wire, w .

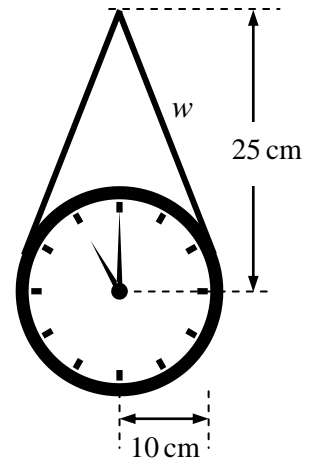
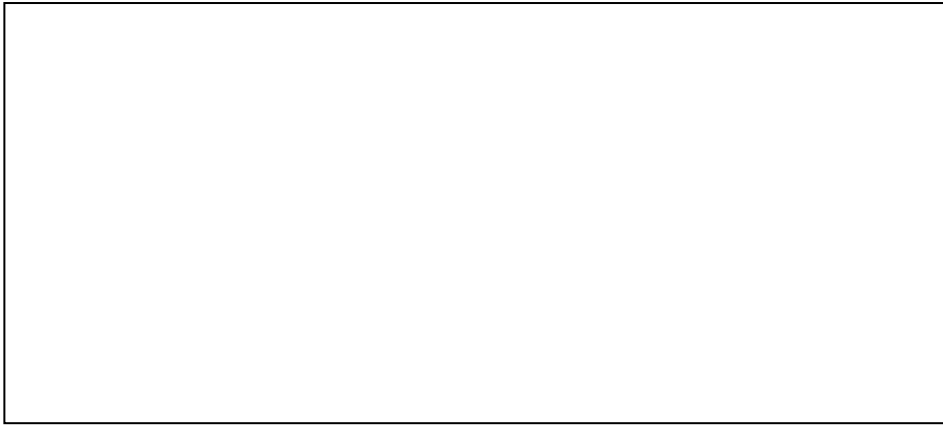

- Q4.**

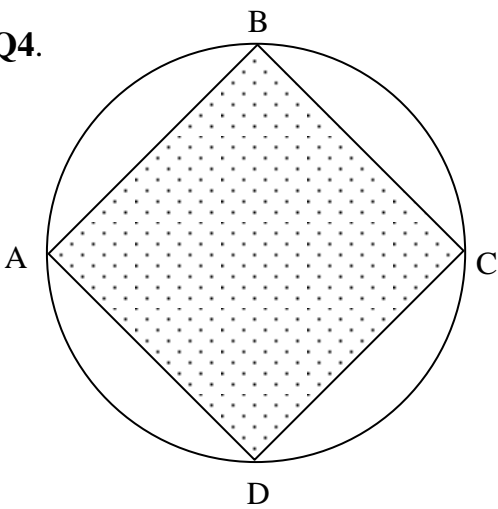

The diagram shows a circle of radius 6 cm with a square ABCD drawn with its vertices on the circumference.

Calculate the unshaded area surrounding the square.

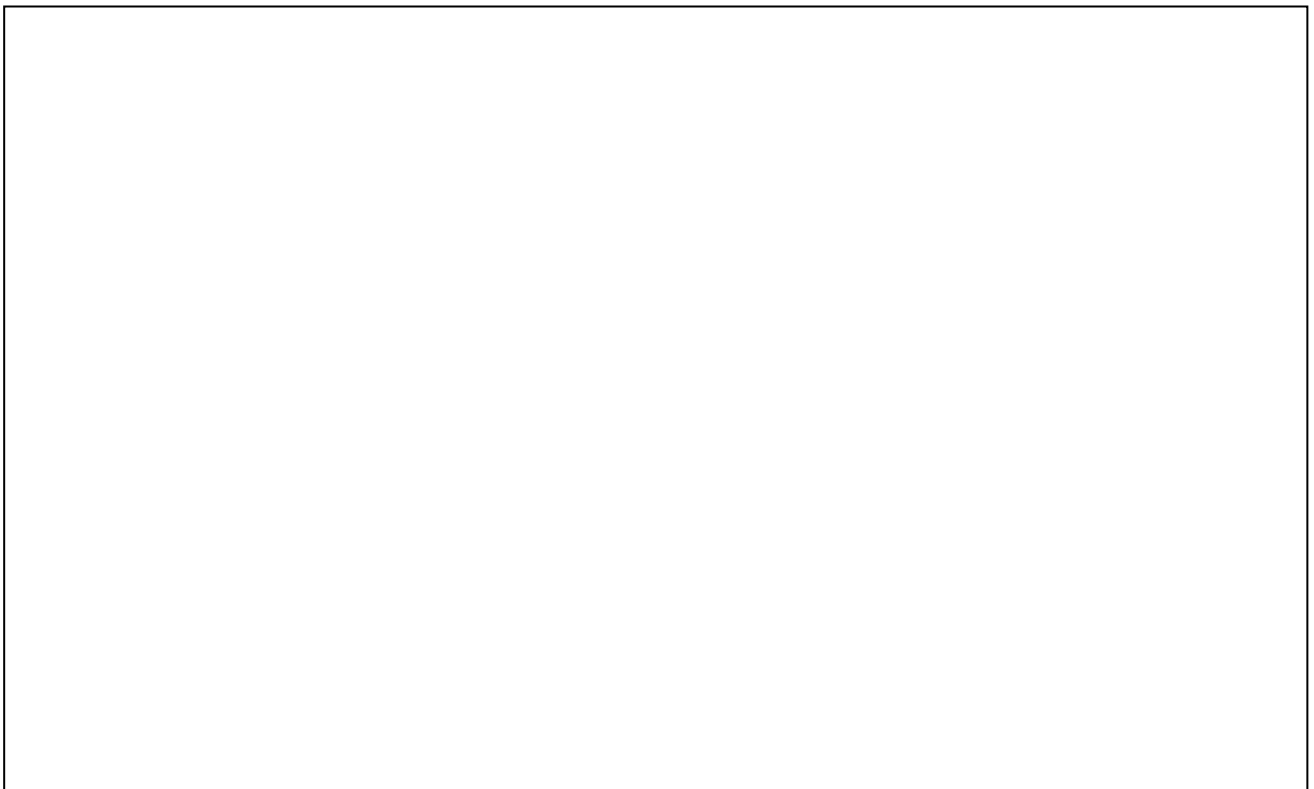

S4 National 5 Homework

The Circle 2

Name

Class

Mark

Q1. Find the sizes of the missing angles in the diagrams below. In each diagram AB is a diameter.

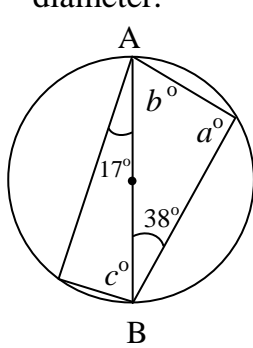

a
b
c

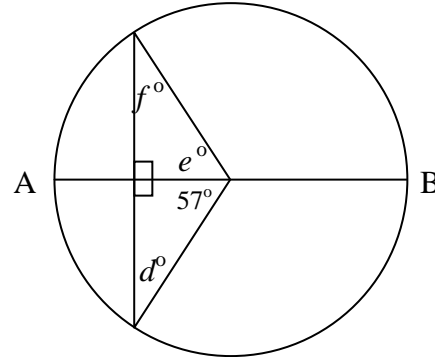

d
e
f

Q2. Calculate the length d in each of the diagrams below.

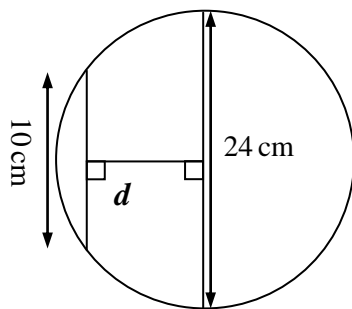
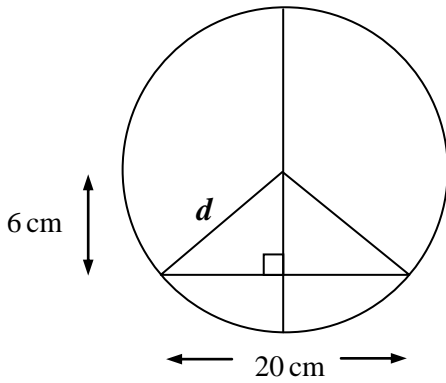

Q3. Find the size of angle x° .

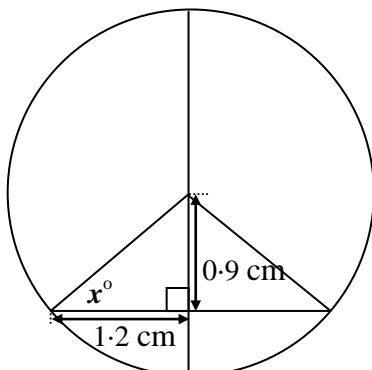

Q4. Find the length marked x in the diagram below.

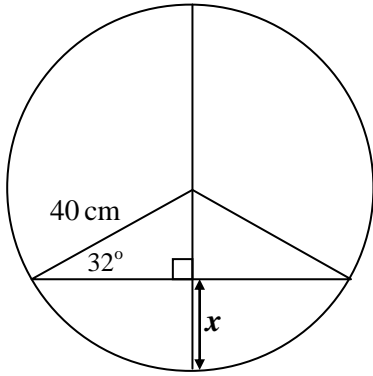

Q5. The diagram shows a section of a disused mineshaft whose diameter is 2.8 metres. The surface of the water in the shaft, PQ, is 180 cm.

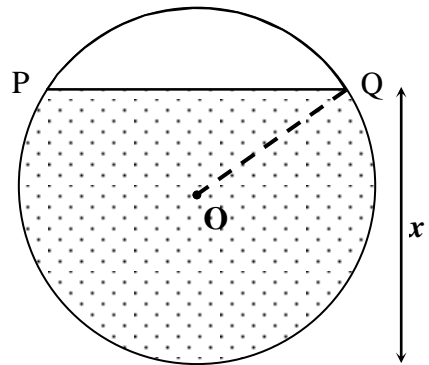

(a) Write down the length of OQ.

(b) Calculate the depth of water in the pipe, x .
(Give your answer to the nearest cm.)

Q6.

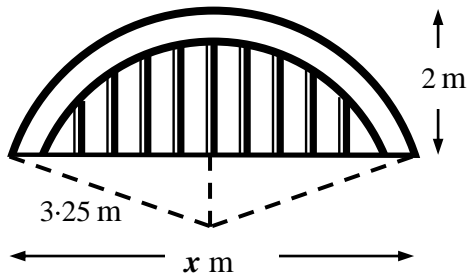

A pedestrian bridge in the shape of an arc of a circle crosses a stream. The radius of the circle is 3.25 m and the height of the bridge is 2m.

Find the length of the bridge, x .

S4 National 5 Homework
The Circle 3

Name

Class

Mark

Q1. Find the length of the minor arc AB in the circle below.

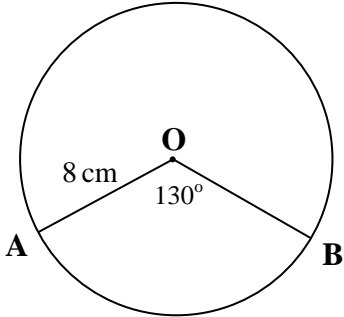

Q2. Find the length of the major arc PQ in the circle below.

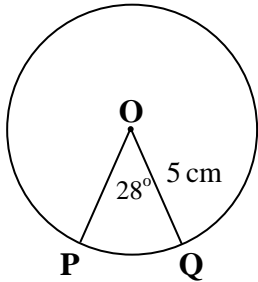

Q3. The length of arc CD is 8.8 cm. Calculate the circumference of the circle.

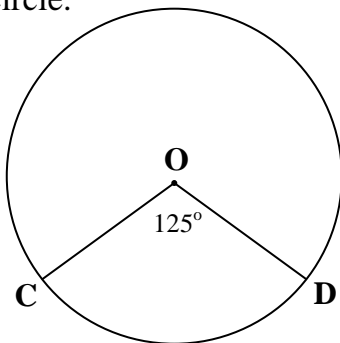

Q4. The area of sector OPQ is 100 cm^2 . Calculate the size of angle x° .

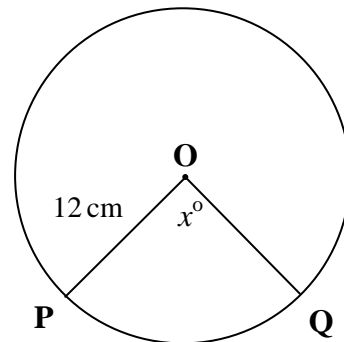

- Q5.** The area of the shaded sector is 36.3 cm^2 . Calculate the area of the circle.

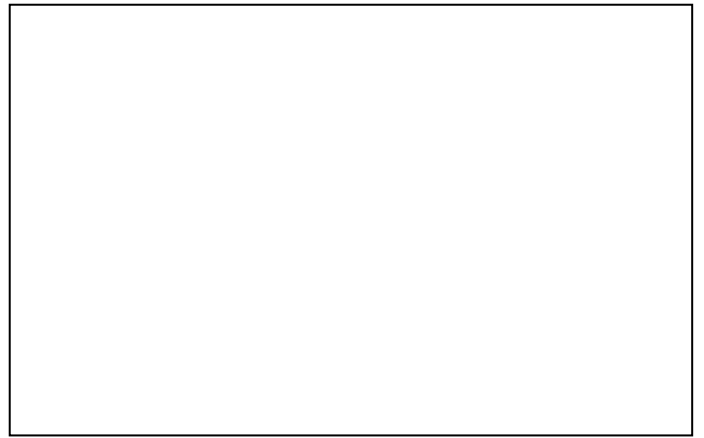
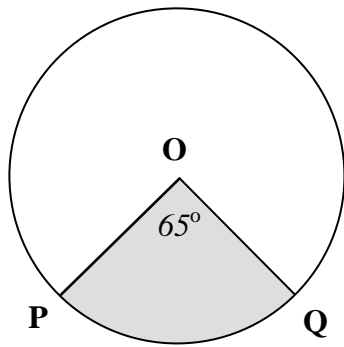

- Q6.** Ornamental paving slabs are in the shape of part of a sector of a circle. Calculate the area of the slab shown.

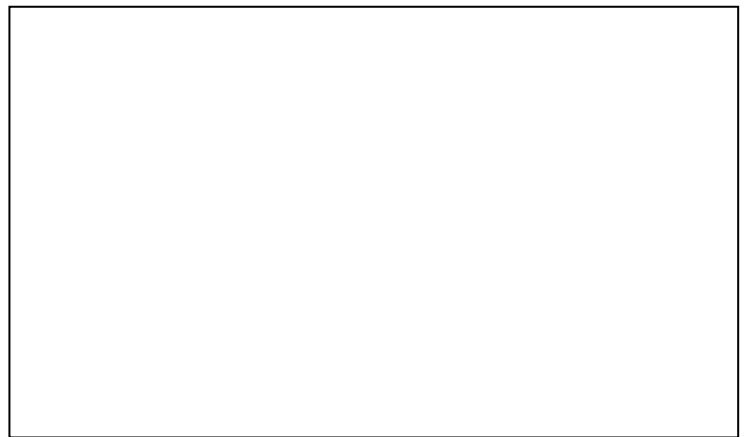
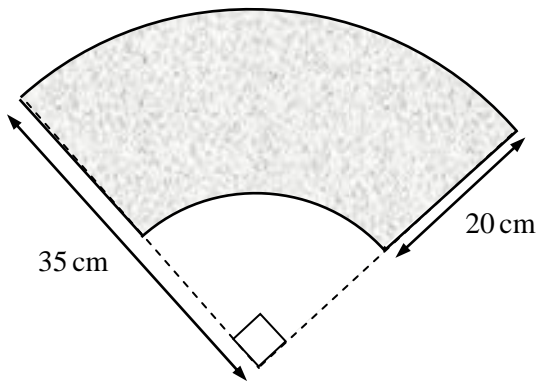

- Q7.** The diagram shows the logo for the Westminster Wine Glass Company. Find the perimeter of the top part of the logo.

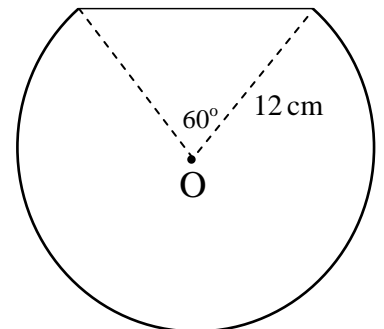
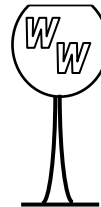

S4 National 5 Homework

Inequalities

Name

Class

Mark

Q1. Solve the inequalities below.

(a) $3x - 1 < 11$

(b) $5y + 3 \geq -12$

(c) $7a - 2 \leq -9$

Q2. Solve these inequalities

(a) $4(2x - 1) + 5 \leq 19$

(b) $8 - 2(w + 3) > 10$

(c) $(b + 1)^2 \leq (b + 3)(b - 2)$

Q3. Bob loads his barrow with bricks. Each brick weighs 4 kg, the barrow weighs 50 kg and Bob weighs 70 kg. The plank of wood can take no more than 170 kg safely.

Form an inequality and solve it to find the largest number of bricks that Bob can safely take across the plank.

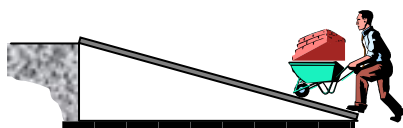

S4 National 5 Homework

Trigonometry 1

Name

Class

Mark

- Q1.** A movement detector beam shines from the top corner of a room (A) to the bottom of a door (B). Calculate the length of the beam to the nearest centimetre.

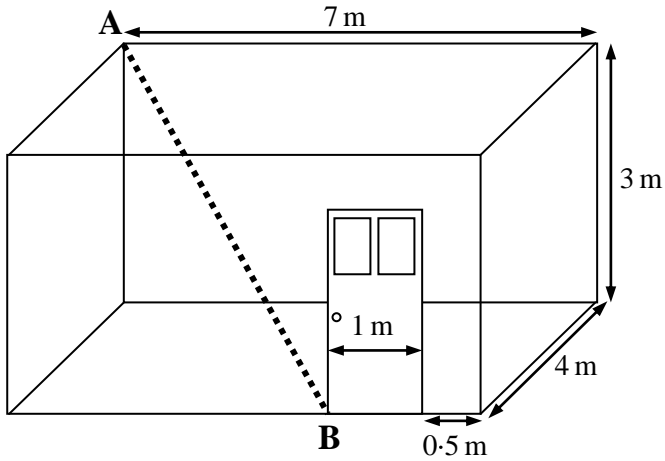

- Q2.** Write down the exact values of :

(a) $\sin 60^\circ$

(b) $\tan 225^\circ$

(c) $\cos 300^\circ$

(d) $\sin 315^\circ$

- Q3.** Write down the equation of each graph shown below

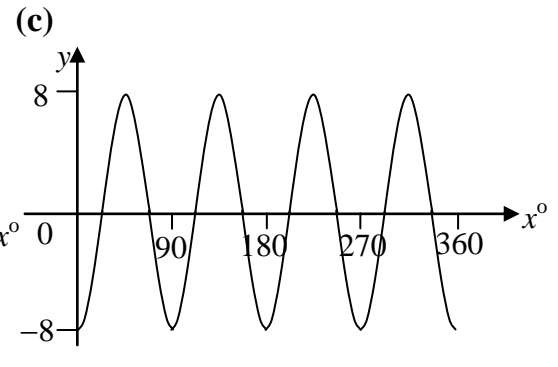
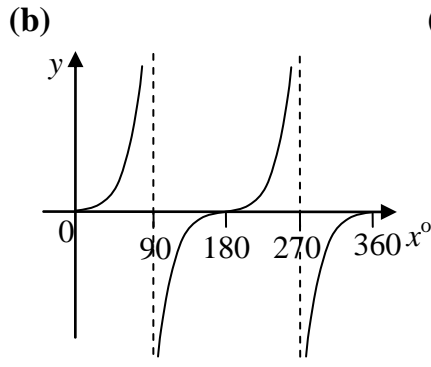
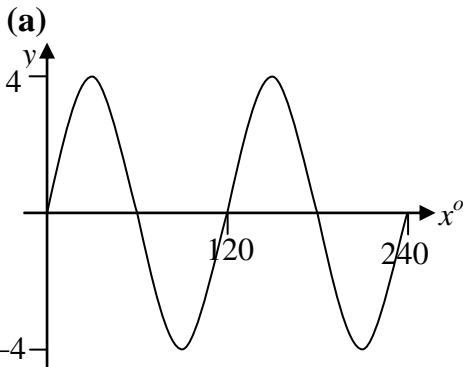

- Q4.** Write down the period of the following

(a) $y = 3 \cos 2x^\circ$

(b) $y = 2 \sin 5x^\circ$

(c) $y = 4 \cos \frac{1}{2} x^\circ$

Q5. Make a neat sketch of the function $y = 4 \sin 2x^\circ$, $0 \leq x \leq 360$, showing the important values.

Q6. Solve the following equations for $0 \leq x \leq 360$

(a) $8 \tan x^\circ - 3 = 2$

(b) $\frac{3}{4} \sin x^\circ = -\frac{1}{2}$

(c) $4 \cos^2 x - 1 = 0$

Q7. $\cos a^\circ = \frac{5}{13}$ and $0 < a < 90$. Find the exact value of $\sin a^\circ$ and $\tan a^\circ$.

S4 National 5 Homework
Quadratic Equations

Name

Class

Mark

Q1. Solve these quadratic equations algebraically.

(a) $5x^2 - 15x = 0$

(b) $6x^2 - 7x - 3 = 0$

Q2. Solve the equation $3x^2 - 3x - 5 = 0$, giving your answer correct to 2 decimal places.

Q3. Solve the equation $4x(x - 2) = 7$, giving your answer correct to 1 decimal place.

Q4.

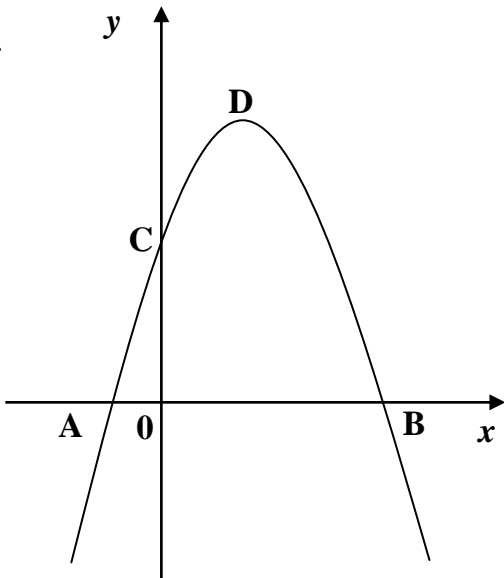

The graph shows the parabola $y = 16 + 6x - x^2$.
Find the coordinates of A, B, C and D.

Q5.

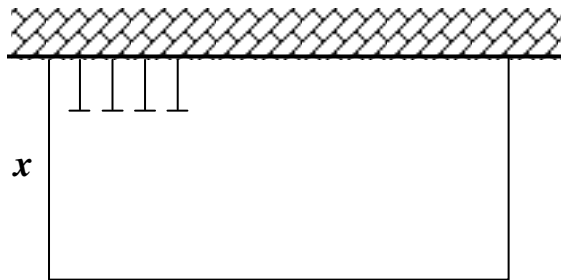

A local council wants to fence off an area next to a wall for car parking.
The council has 300 m of fencing and wants to fence off an area of 7200 m^2 .

What length, x , should the council make the car park?

S4 National 5 Homework

Proportion

Name

Class

Mark

Q1. The results of an experiment are shown in the table below.

A	0.1	0.2	0.3	0.4	0.5	0.6
B	2	4	6	8	10	12

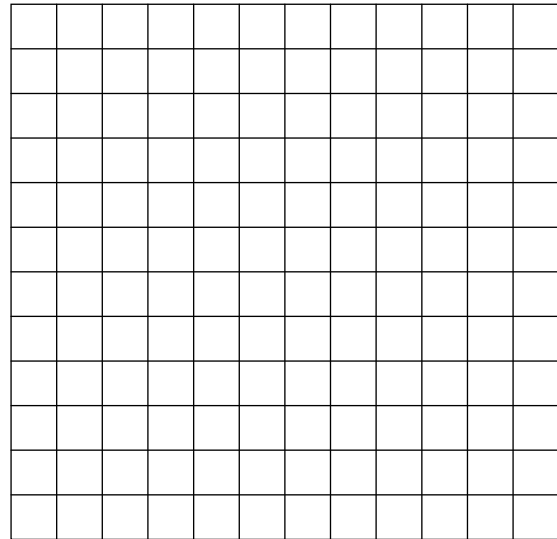

(a) Show these results on a graph and give a reason why the quantities are in direct proportion.

(b) Find a formula connecting the two quantities.

Q2. The cost (£C) of a train journey is directly proportional to the number of miles travelled (M). A 600 km trip costs £75. Find a formula connecting C and M and use it to calculate the cost of a 1500 km journey.

Q3. The volume of a sphere (V) varies directly as the cube of its radius (r). A sphere of radius 10 cm has a volume of 4200 cm^3 . Find an equation connecting V and r and calculate the volume of a cube of radius 5 cm.

- Q4.** The time taken to complete a journey of a fixed distance varies inversely with the speed. If it takes a cyclist 1hr 30 mins travelling at 40 km/h to complete the journey, how long will it take a walker travelling at 5 km/h?

- Q5.** The weight (W) of an object varies inversely as the square of the distance (d) from the centre of the earth. The radius of the earth is 6400km and an astronaut on the surface weighs 90 kg. What will he weigh 625 km above the surface of the earth? (to nearest kg)

- Q6.** The weight, W , that a horizontal beam can support varies jointly as the breadth, b , and the square of the depth, d , and inversely as the length of the beam, L .

A 10cm by 10 cm beam which is 300 cm long can support a load of 120 kg.

Write the equation for this variation and calculate the load that could be supported by a beam that has breadth 10 cm, depth 15 cm and length 480 cm.

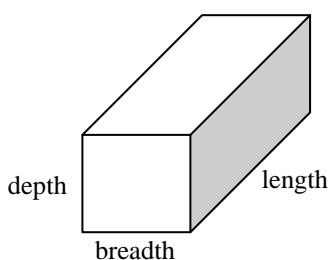

S4 National 5 Homework
Statistics

Name

Class

Mark

Q1. A set of test marks is shown below.

28 26 34 37 27 44 21 27 18 23 26 27 13

Use an appropriate formula to calculate the mean and standard deviation.

Q2. (a) A quality control examiner on a production line measures the weight in grams of cakes coming off the line. In a sample of eight cakes the weights were

150 147 148 153 149 143 145 151

Calculate the mean and standard deviation.

(b) On a second production line, a sample of 8 cakes gives a mean of 149 and a standard deviation of 6.1. Compare the two production lines.

Q3. (a) The price in pounds of the same model of car in eight different car dealerships is shown below.

5800 6100 6100 5900 5800 6000 5800 5800

(b) In eight independent showrooms the mean price was £6000 with a standard deviation of 212.

Compare the independent prices with those of the dealerships.

Q4. A manager keeps a record of the number of mistakes his employees make.

employee	A	B	C	D	E	F	G	H	I
number of mistakes	10	15	11	4	17	23	11	12	10

He knows that if all the data lies between the mean and 3 standard deviations above or below the mean then there is not a problem with his employees.

Does this manager have a problem with this group of employees?

S4 National 5 Homework

Surds

Name Class Mark **Q1. Evaluate**

(a) $\sqrt[3]{125^2}$

(b) $(\sqrt[4]{16})^5$

(c) $\sqrt[3]{64} \times \sqrt[4]{81}$

Q2. Simplify

(a) $\sqrt{150}$

(b) $\sqrt{44}$

(c) $\sqrt{63}$

(d) $\sqrt{2} \times \sqrt{32}$

(e) $\sqrt{2} \times \sqrt{10}$

(f) $\sqrt{24} \times \sqrt{3}$

Q3. Express each of the following in its simplest form.

(a) $\sqrt{12} + \sqrt{27}$

(b) $\sqrt{72} - \sqrt{50}$

(c) $\sqrt{1000} - \sqrt{90}$

Q4. Write in index form

(a) $\sqrt[3]{a}$

(b) $\sqrt[3]{p^5}$

(c) $\frac{1}{\sqrt[4]{y}}$

Q5. Express with a rational denominator and simplify where possible

(a) $\frac{35}{\sqrt{7}}$

(b) $\frac{8}{3\sqrt{2}}$

(c) $\frac{\sqrt{15}}{\sqrt{5}}$

Q6. Express with a rational denominator

(a) $\frac{4}{1+\sqrt{3}}$

(b) $\frac{3}{2-\sqrt{6}}$

(c) $\frac{12}{\sqrt{10}-\sqrt{2}}$

Q7. In triangle PQR, PQ is 20cm and QR is 10 cm.

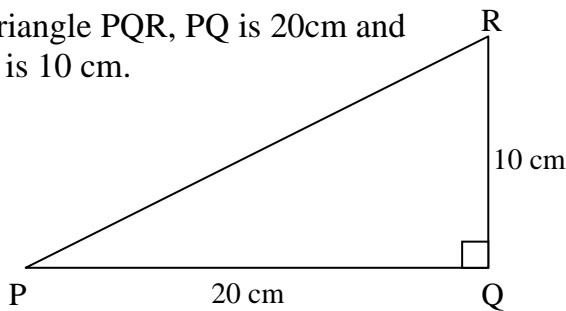

Calculate the length of PR giving your answer as a surd in its simplest form.

Q8.

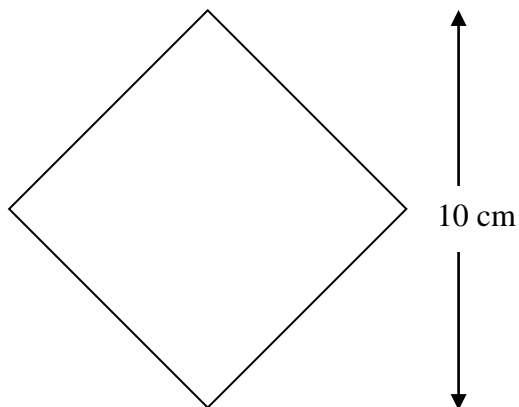

The diagonal of this square is 12 cm.
Find the length of the side and express it as a surd in its simplest form

S4 National 5 Homework

Indices

Name Class Mark

Q1. Evaluate each of the following for $a = 81$ and $x = 8$.

(a) $3a^{3/4}$

(b) $5x^{2/3}$

(c) $a^{-1/4} \times x^{1/3}$

Q2. Simplify :

(a) $3x^{1/5} \times 5x^{-1/5}$

(b) $4x^{1/2} \times 3x^{7/2}$

(c) $27x^{1/4} \div 3x^{-3/4}$

Q3. Solve these equations to find n .

(a) $3^n = 243$

(b) $4^{2n} = 256$

(c) $9^n = \frac{1}{729}$

Q4. Express each of the following in index form with x in the numerator.

(a) $\frac{1}{3\sqrt{x}}$

(b) $\frac{x^2}{\sqrt[4]{x}}$

(c) $\frac{\sqrt{x}}{x^2} - \frac{1}{2x^3}$

Q5. Express each of the following as a sum or difference of terms.

(a) $(x^3 - x)(x^2 + 3)$

(b) $\frac{1}{x^3}(x^6 + x)$

(c) $x^{1/3}(x^2 - \sqrt[3]{x})$

Q6. Express in surd form

(a) $y^{\frac{2}{3}}$

(b) $b^{\frac{3}{4}}$

(c) $c^{\frac{3}{2}}$

(d) $c^{-\frac{1}{3}}$

(e) $3y^{\frac{1}{3}}$

(f) $2z^{-\frac{1}{2}}$

Q7. The formula for the number of bacteria in a biology lab sample is $N = 1 \cdot 3^d$, where d is the number of days

(a) Draw the graph for $d = 0, 2, 4, 6, 8, 10$

working

(b) Use your graph to estimate the number of bacteria after 7 days.

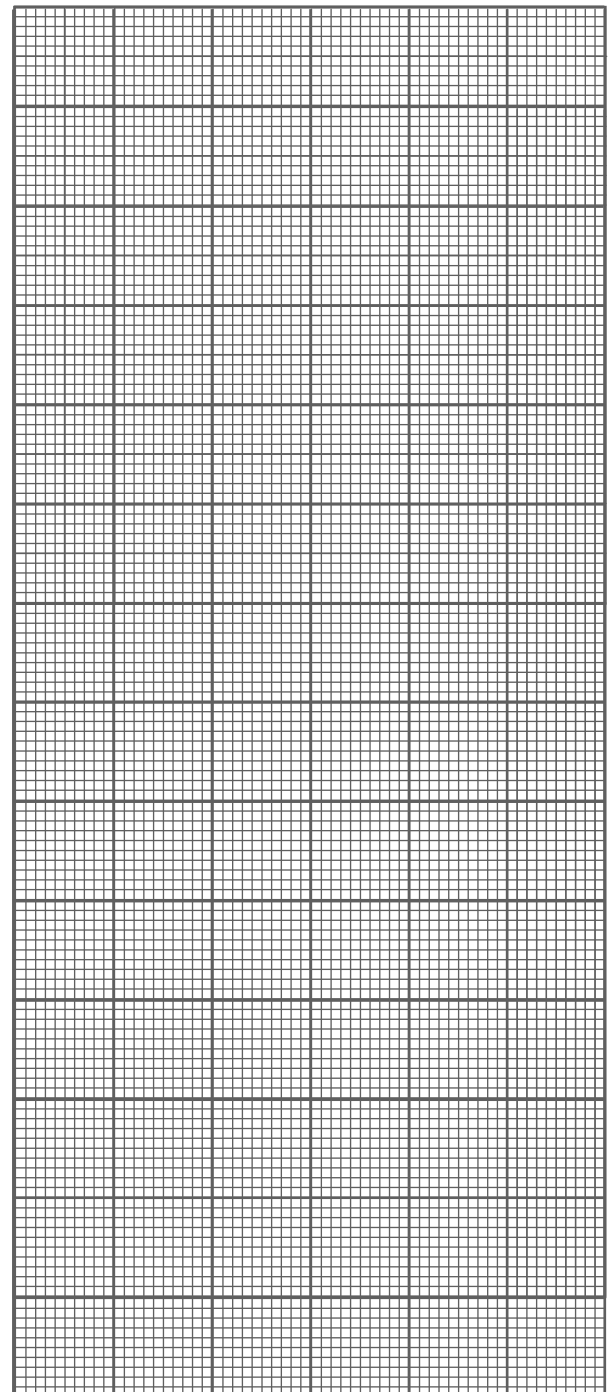

S4 National 5 Homework

Trigonometry 2

Name

Class

Mark

Q1. Calculate x in each triangle shown below.

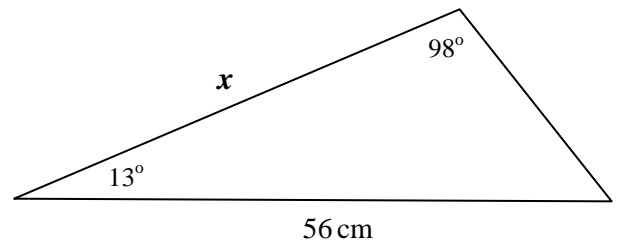
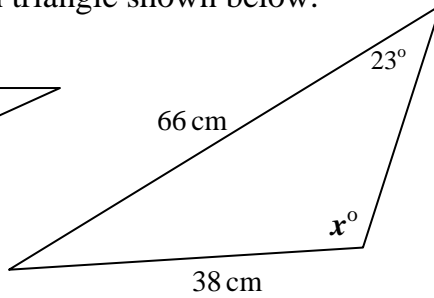
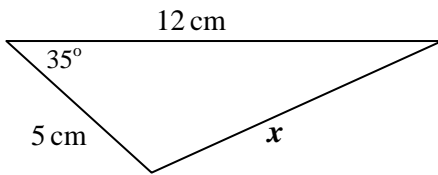

Q2. Three oil platforms, Alpha, Gamma and Delta are situated in the North Sea as shown in the diagram.

The distances between the oil platforms are shown in the diagram.

If the bearing of Delta from Alpha is 125° , what is the bearing of Gamma from Alpha?

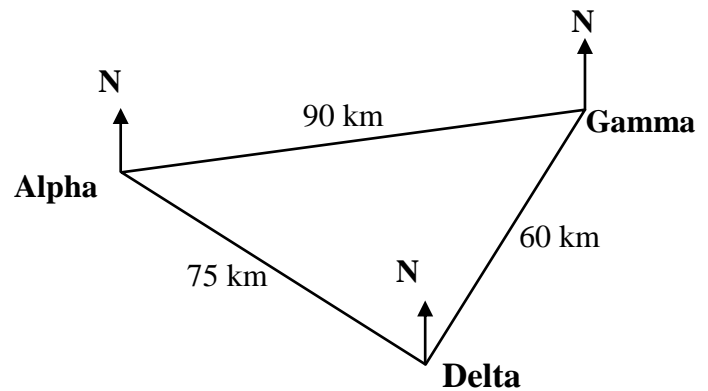

- Q3.** On an orienteering course, Ian follows the direct route through a forest from A to C while Kate follows the road which goes from A to B and then from B to C.

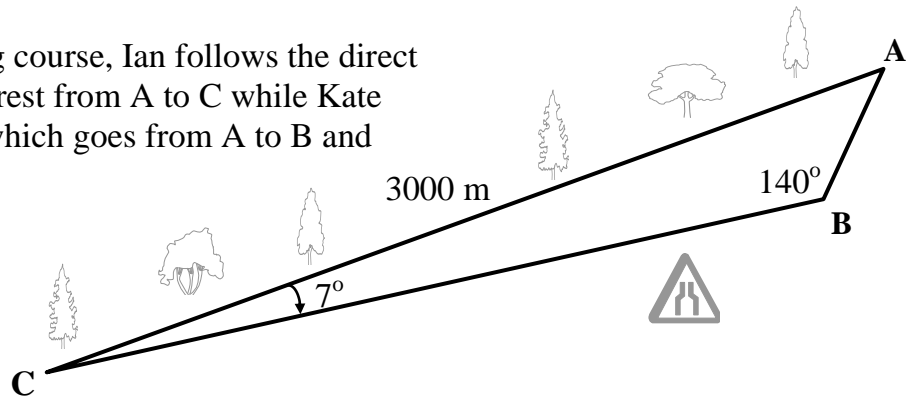

Calculate the total distance which Kate has to travel from A to C.

- Q4.** A small boat race travels round a set of three buoys to cover a total distance 35 km.

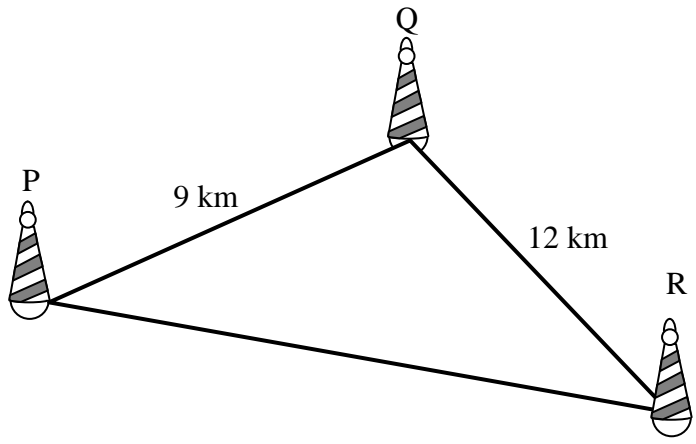

(a) Calculate the size of angle PQR.

(b) Calculate the area of triangle PQR

S4 National 5 Homework
Fractions & Equations

Name

Class

Mark

Q1. Simplify the following fractions:

(a) $\frac{ab^2}{abc}$

(b) $\frac{4k}{8k-2m}$

(c) $\frac{ab-3b}{5a-15}$

(e) $\frac{4x^2-25}{2x^2+x-15}$

(f) $\frac{2x^2+11x+5}{3x^2+14x-5}$

(g) $\frac{a+1}{1-a^2}$

Q2. Add or subtract the following:

(a) $\frac{1}{2x} + \frac{2}{3x}$

(b) $\frac{2x-1}{3} + \frac{x+2}{5}$

(c) $\frac{5}{2x+3} - \frac{2}{5x}$

Q3. Multiply or divide the following, giving your answer in its simplest form

(a) $\frac{2p}{q^2} \div \frac{p^2}{q}$

(b) $\frac{a^2+ab}{b} \times \frac{b}{a+b}$

(c) $\frac{x^2-4}{6} \div \frac{x^2+8x+12}{3}$

Q4. Solve these equations

(a) $\frac{x}{2} - \frac{x}{3} = 4$

(b) $\frac{x+3}{4} + \frac{x}{2} = 6$

(c) $\frac{2}{3} - \frac{x+1}{9} = \frac{5}{6}$

(d) $\frac{x+2}{5} + \frac{2x-1}{3} = 7$

(e) $\frac{3x}{20} + \frac{x-2}{8} = \frac{3}{10}$

(f) $\frac{1}{3x} - \frac{x-2}{4} = \frac{1}{6}$

Q5. The perimeter of this rectangle is $\frac{2x+2}{x^2}$ cm

and its breadth is $\frac{1}{x}$ cm.

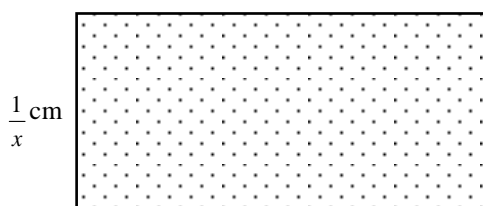

Find the length of the rectangle.

S4 National 5 Homework
Mixed Exercise 1

Name

Class

Mark

Q1. A function f is defined by $f(x) = 2x^{1/2}$. Find a when $f(a) = 16$.

Q2.

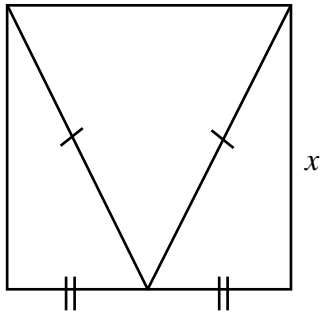

A square of side x has an isosceles triangle inside it.

Show that perimeter, P , of this triangle can be expressed as

$$P = x(1 + \sqrt{5})$$

Q3. Express $\left(x^{1/2} - 2x^{-3/4}\right)\left(x^{3/4} - 2x^{-1/2}\right)$ without brackets in its simplest form.

Q4. The diagram shows part of the graph of $y = x^3 - 3x + 5$.

The equation $x^3 - 3x + 5 = 0$ has a root that lies between $x = -2$ and $x = -3$.

Find this root correct to 1 decimal place.

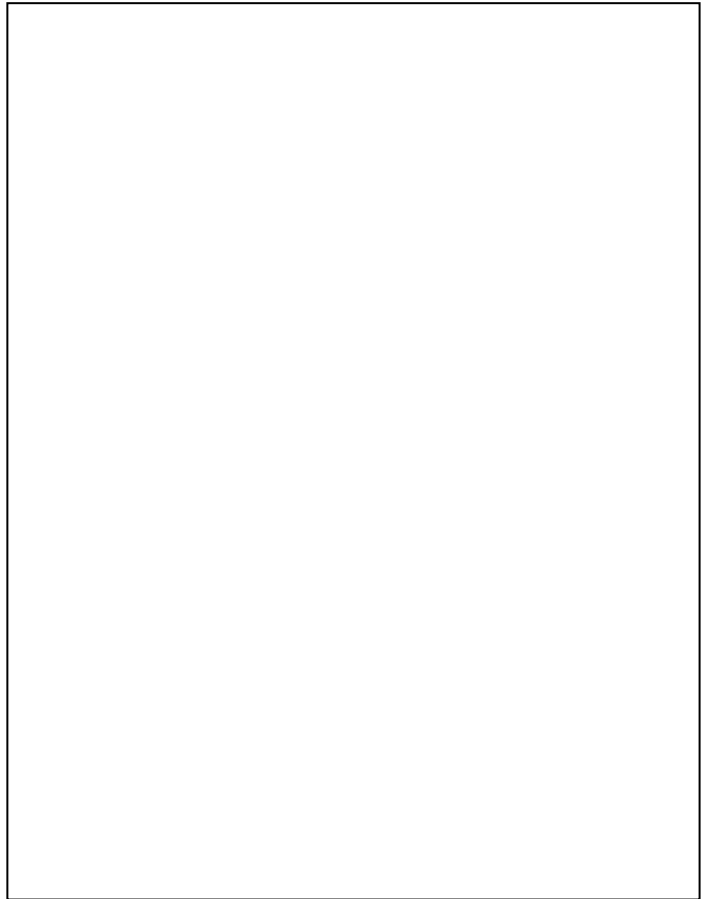
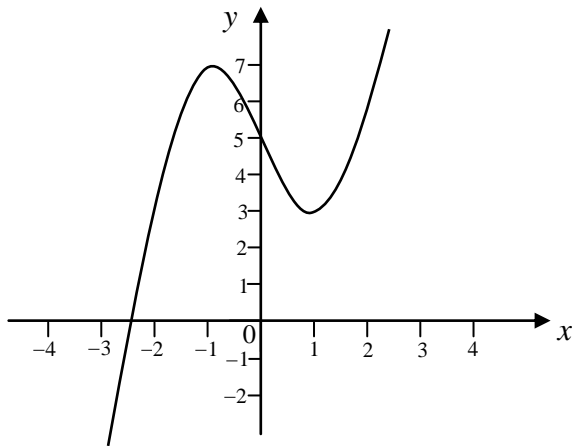

Q5. The heat, H , lost through a wall varies jointly as the area of the wall, A , and the difference between the inside and outside temperature, d .

A wall with area 12 m^2 , an outside temperature of 2°C and an inside temperature of 20°C , loses 324 watts of heat.

Calculate the heat loss for a 15 m^2 wall with an outside temperature of 5°C and an inside temperature of 19°C .

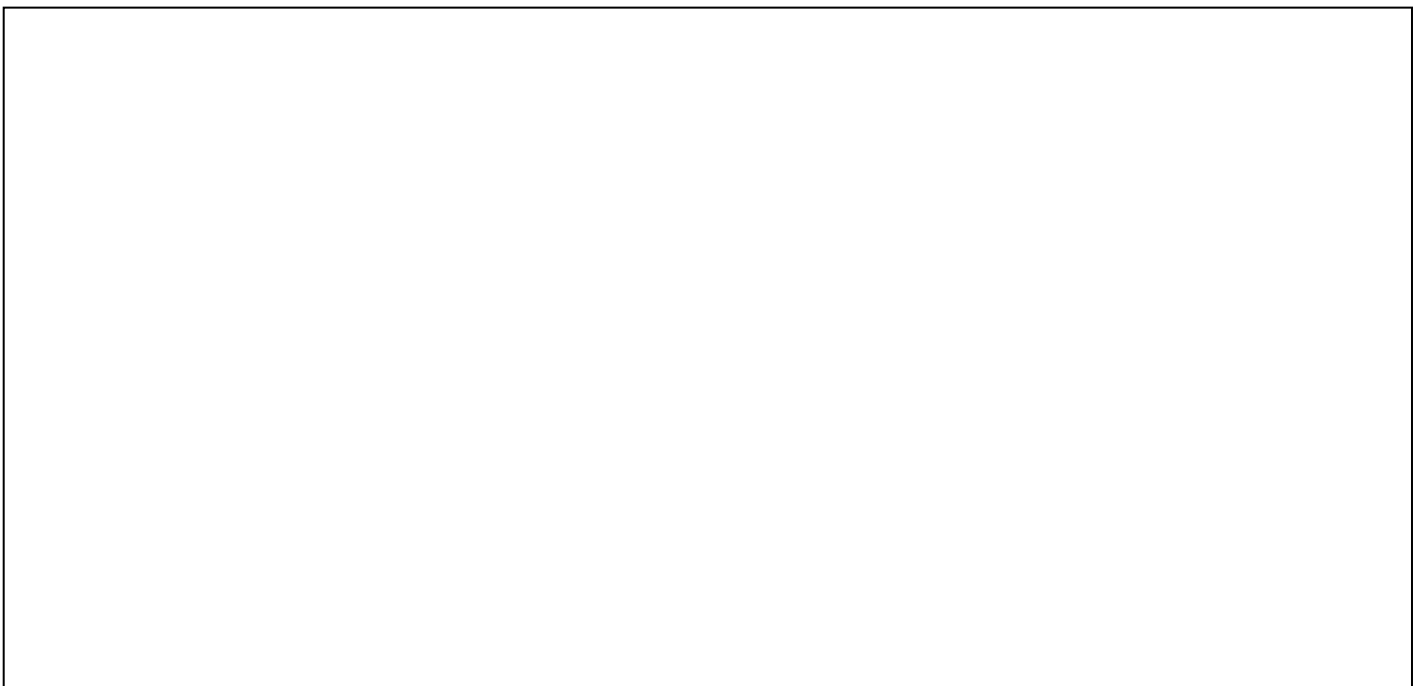

S4 National 5 Homework
Mixed Exercise 2

Name

Class

Mark

Q1. Multiply out the brackets and simplify $(2x + 3y)(4x - 5y)$

Q2. The Brown Box company produces a range of boxes in the shape of cubes where the length of each box is $\frac{2}{3}$ that of the previous one.

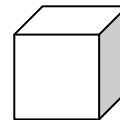
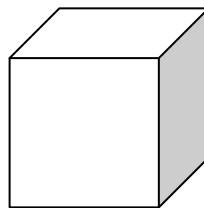
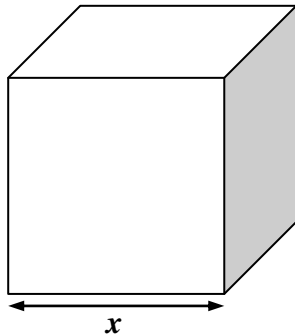

(a) If the length of the first box is x , show that the surface area of the second box is $\frac{8}{3}x^2$.

(b) If the **volume** of the **third** box is 216 cm^3 , find the length of side of the **first** box.

Q3. Express as a single fraction in its simplest form: $\frac{2}{3x} + \frac{5}{x-1}$

Q4. In the triangular field is shown below, $AB = 74$ m, $BC = 80$ m and the area of the field is 2780 m².

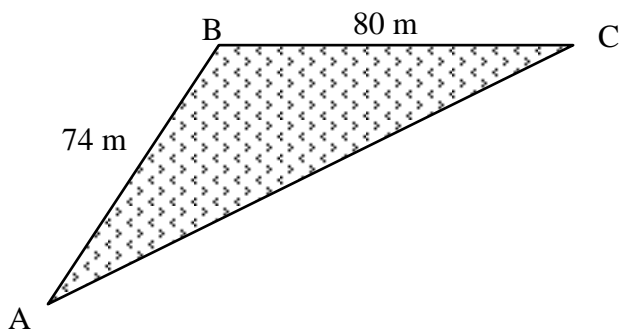

(a) Find the size of the obtuse angle ABC.

(b) Calculate the corresponding length of AC.

S4 National 5 Homework
Mixed Exercise 3

Name

Class

Mark

Q1. Change the subject of the formula to x : $A = 5 - 4\sqrt{x}$

Q2. Four burger meals and three hot-dogs cost £10.
Two burger meals and four hot-dogs cost £7.
Form a system of equations and solve it to find the cost of each burger meal and hot-dog.

Q3. Factorise fully:

(a) $12x^2 - 27$

(b) $6x^2 + 11x - 30$

- Q4.** A company's profit for the year was $\pounds 1.2 \times 10^8$.
Calculate the profit made per day, giving your answer to the nearest \pounds .

- Q5.** Mr. Park's house has a square porch at one end. He decides to build a semi-circular patio onto the end of the house. The plan view is shown below :

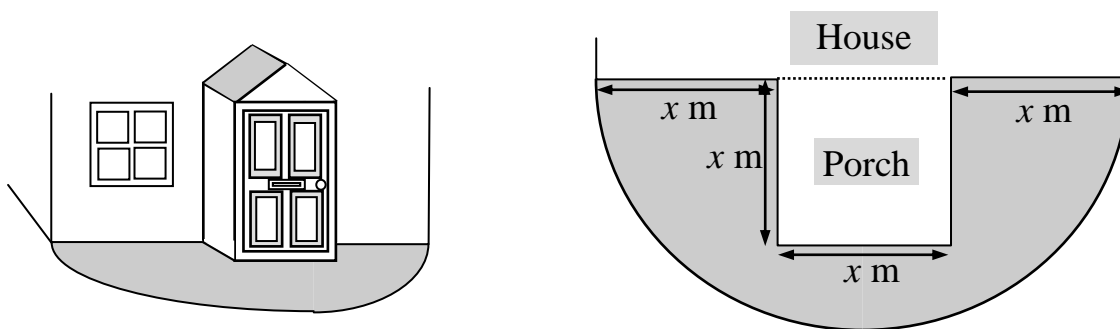

He plans to make the patio from concrete, using a uniform depth of **10 cm**.

- (a) Show that the volume of concrete required is $\frac{1}{80}x^2(9\pi - 8) \text{ m}^3$

- (b) Find the volume of concrete needed if $x = 2$.

S4 National 5 Homework
Mixed Exercise 4

Name

Class

Mark

Q1. Triangles PQT and PRS are shown opposite.

QT = 8 cm, RS = 10 cm and TS = 4 cm.

Triangle PQR is similar to triangle PST.

Calculate the length of PT.

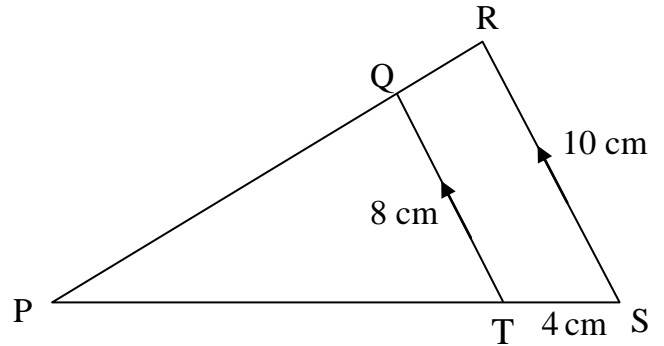

Q2. On a journey to visit a friend Jan leaves her house and travels at an average speed of 60 km/h. On the return journey her average speed is 75 km/h. The total time for her journey was $6\frac{3}{4}$ hours.

Form an equation and solve it to find the distance from Jan's house to her friend's house.

Q3. Express as a surd in its simplest form $\sqrt{75} - \sqrt{3} + \sqrt{27}$

Q4.

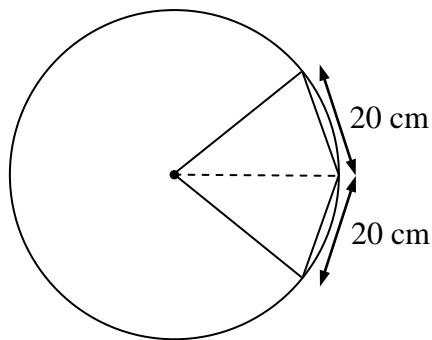

The diagram shows a kite made from two congruent isosceles triangles with one vertex on the centre of a circle and the other three vertices on the circumference.

The shorter sides of the kite are each 20 cm.
The area of the kite is 480 cm^2 .

Calculate the radius of the circle.

Q5. The amount, A grams, of a radioactive isotope decreases with time according to the formula $A = 80 \times 2^{-t}$ where t is the time in years.

(a) Calculate the amount of the isotope remaining after 4 years.

(b) How much of the isotope will remain after a **further** 4 years?

S4 National 5 Homework
Mixed Exercise 5

Name

Class

Mark

Q1. Solve the inequality

$$3 - 4(3x - 1) \geq 3(1 - 2x)$$

where x is a **positive integer**.

Q2.

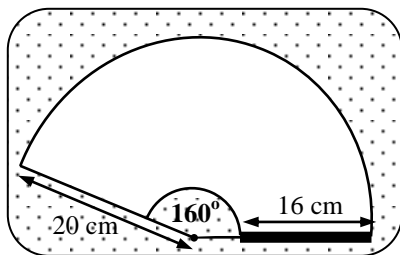

The headlamp wiper on a car traces out the arc of a circle, radius 20 cm. The angle at the centre is 160° . The length of the wiper blade in contact with the lamp is 16 cm. Calculate the area of the headlamp that is cleared by the blade.

Q3. $f(x) = 3x^{-\frac{1}{2}}$

Find the value of $f(5)$, giving your answer as a fraction with a rational denominator.

- Q4.** Two perfume bottles are similar.
The smaller is 10 cm in height and
the larger 11.9 cm.

The smaller one contains 30 ml.
What does the larger one contain?
(Answer to nearest ml)

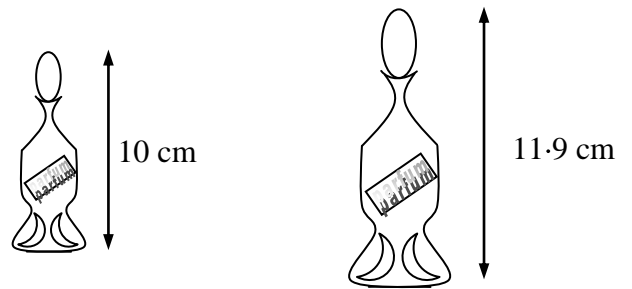

- Q5.** A satellite is orbiting the earth and its distance D km, north of the equator, is given by the formula $D = 500 \sin(200t)^\circ$, where t is the time in hours after 12 midnight.
- (a) What is the maximum distance the satellite is north of the equator?

- (b) What will be the first two times that the satellite is 250 km north of the equator?